



LEVELSYSTEM



PERSEN VAN HYDRAULISCHE SLANGEN.
VERPRESSEN HYDRAULIK SCHLÄUCHE.
PRESSING HYDRAULIC HOSES.
SERTISSAGE DES RACCORDS HYDRAULIQUES.



Meten op het vlakke deel, NIET op de ribbel
 Gemessen auf dem Flachteil, NICHT auf dem Grat
 Measured on the flat part, NOT on the ridge
 A mesurer sur la partie plate et non sur le renflement

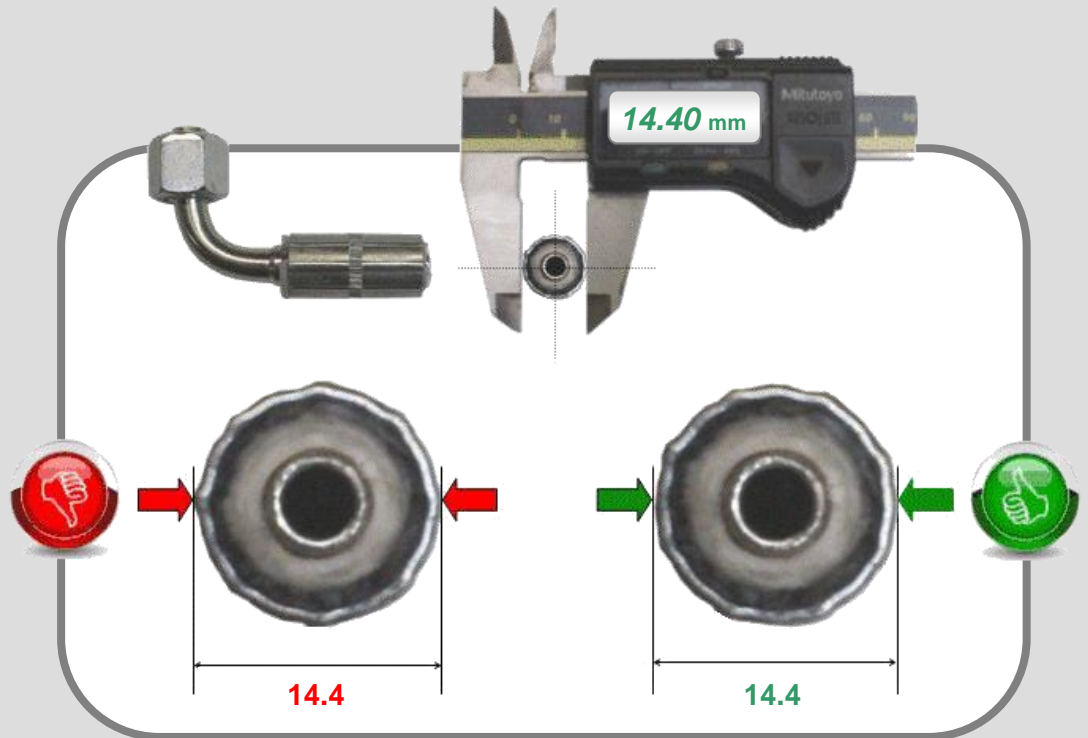

X 14,3 X

AFKEUR

FEHLER

WRONG

ERREUR

14,4 - 14,5 - 14,6

GOEDKEUR

OK

GOOD

BON

X 14,7 X

AFKEUR

FEHLER

WRONG

ERREUR

→ 14,4 mm. 0 / + 0,2 ←

Juiste Persmaat
 Richtiges Pressmaß
 Correct Press size
 Pression correcte de sertissage

